

Biology 7 Laboratory Manual

By Professor Sara Huang

Spring 2012

Biology 7 Lab Requirements

1. Follow the class policies listed in class syllabus and Schedule of Class of Los Angeles Valley College.
2. Please do not eat or drink in the classroom
3. **You may be prohibited from attending lab by wearing open –toe shore or not have gloves with you on the days of dissection.. The points you lose may not be made up.**
4. The college does not provide gloves and lab coat. Please make sure that you purchase your own gloves and a lab coat (if you prefer to wear one).
5. Read your lab manuals before coming to the lab. Each lab answer sheet usually contains a preview of next lab.
6. Clean after yourself after each lab by wiping clean the lab bench with soap.
7. All dissection tools have to be clean and dried to avoid losing lab points.
8. No break shall be taken for more than 10 minutes during the lab.
9. Work as a group. However, **finish your write up individually**. Otherwise you will get zero.

Lab 1 Scientific Inquire and Measurement

Pre-lab Reading:

Reece et.al. 2011. *Biology* Chapter 1 pages19-25 and Appendix B

Objectives

1. Be able to define scientific methods.
2. Be able to define qualitative observation, quantitative observation and the metric system.
3. Be able to identify the commonly used tools.
4. Be able to explain and measure length, volume, mass in metric units; temperature in degree Celsius.

Introduction

A. Scientific Methods

There are different ways for biologists to investigate life. Some people make observations, some utilize data to build models and still others use experiment based inquiry to study life. In this lab, we will explore the experiment based scientific investigation.

A typical step by step problem solving method used in Biology is called **scientific method**. There are variations of the scientific method. However, the typical scientific method involves **observation, hypothesis, experiment, result and conclusion**.

Observation allows one to see certain phenomena either through observing nature or through reading of scientific literatures. One might raises questions about observed phenomena.

Hypothesis is developed to tentatively explain the cause of phenomena or answer the questions. Hypothesis is an educated guess. One of these hypotheses is going to be rejected and another will be accepted after the experimentation. People do not prove hypotheses wrong or right.

An experiment is designed to test the hypotheses. A common experiment employed by Biologists is called a **controlled experiment**, where a control group is compared with an experimental group. These two groups only differ by one factor, which is the condition being tested. The rest of conditions have to constant among the control groups and experimental groups. During the designing of any experiment, one must identify the factors in which the experiments are conducted, the types of measurements (data collections) and **independent and dependent variables**. The independent variables are the causes; the dependent variables are the results of causes.

There are two types of data: **qualitative and quantitative** data. The qualitative way is to make observations and describe the characteristics of certain objects; numerical observation is not used in qualitative case. A quantitative observation of the same object will have to involve numerical measurements. For example, “Bacteria are very small” is a qualitative observation. “The diameter of bacteria is usually around 5 μ m” is a quantitative measurement.

Once experimental data are collected and analyzed, the researcher can look at the results and make conclusions. If data support the predication generated by null hypothesis, the hypothesis is accepted. Other wise null hypothesis is rejected, the alternative hypothesis is accept. One can either support or falsify the hypothesis, but one can not prove the hypothesis right or wrong.

B. Metrics System

The **metric system** is the standard system of measurement in the scientific world. The metric reference units are the meter for length, the liter for volume, the gram for mass, and the degree Celsius for temperature. Further information and conversions can also be found in Campbell and Reece (2005) Biology book Appendix B.

Materials

For each group:

- 1 30-centimeter ruler with metric and American Standard units on opposite edge.
- 1 meter ruler with metric and American Standard units
- 2 graduated cylinders: 25 ml
- 1 thermometer with both Celsius and Fahrenheit
- 1 triple beam balance

Exercise 1.1 Scientific Method

In this exercise, we will use our height as an example to learn about scientific methods.

A. Observation

Make an observation related to the heights of your follow classmates in class. Record them on your answer sheet.

1. Is everyone at same height?

B. Hypothesis

Make a hypothesis about the most common height in class.

If we classify people into three categories: short (below 165 cm), medium (165-175 cm) and tall (more than 175 cm)

C. Measurements

1. Explain how to measure the height of a person.

Exercise 1.2 Identify the Commonly Used Tools in Biology 7 Labs
--

Use the displays in the back of the lab. Identify the unknown dissecting tools in Figures 1.

A. _____



B. _____



C. _____



D. _____



E. _____



Figure 1 Dissecting Tools

Exercise 1.3 Length

Length is the measurement of a straight-line from one end to the other end. The standard unit is **meter**. Metric units of length measurement commonly used in this lab include the **kilometer (km)**, **meter (m)**, **centimeter (cm)**, **millimeter (mm)**, **micrometer (μm)**, **nanometer (nm)**.

A. Read the measurement of a paper clip as shown in the diagram below

_____.

Figure 2 Length Reading

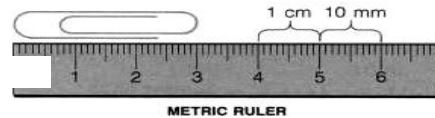

B. Please take a look at your 30 cm small ruler and find out 1 cm = _____ mm,
1 inch = _____ cm

C. Please look at your 1 meter stick and find out 1 m = _____ cm, 1 m = _____ inches.

D. Take five readings of the length of the same index finger and get an average.

Measurement 1 _____ cm

Measurement 2 _____ cm

Measurement 3 _____ cm

Measurement 4 _____ cm

Measurement 5 _____ cm

Average _____ cm

Are these measurements identical and why not?

Write the average length of your index finger on the write board.

E. Complete the Blanks in Table 1

Table 1 Metric Unit of Length

Unit	Value	Exponent Value	Relative Size
Kilometer	1 km = 1000 m	10^3 m	Largest ↓ Smallest
Meter	1 m = _____ cm	10^0 m	
Centimeter	1 cm = _____ mm	10^{-2} m	
Millimeter	1 mm = _____ μm	10^{-3} m	
Micrometer	1 μm = 0.001 mm	10^{-6} m	
Nanometer	1 nm = 0.001 μm	10^{-9} m	

F. Your height in feet is _____. Convert your height from feet to meters_____.

G. Use a measuring tape measure your height in cm._____. Record your name on the board.

H. Record your own height, your average index finger length in the table below and on the write board. Copy other people's numbers from the board as well.

I.

J. Table 2 Measurements of Individual **Height less than 165 cm**

	Height (cm)	Index finger Average (cm)
1		
2		
3		
4		
5		
6		
7		
8		
9		
10		
11		
12		
13		
14		
15		
16		
Class Average		

K. Table 3 Measurements of Individual **Height from 165 -175 cm**

	Height (cm)	Index finger Average (cm)
1		
2		
3		
4		
5		
6		
7		
8		
9		
10		
11		
12		
13		
14		

	Height (cm)	Index finger Average (cm)
15		
Class Average		

L.

M. Table 4 Measurements of Individual Height **from 175 cm and above**

	Height (cm)	Index finger Average (cm)
1		
2		
3		
4		
5		
6		
7		
8		
9		
10		
11		
12		
13		
14		
15		
Class Average		

N. Use the three tables above, count the number of occurrence (frequency) in each category and record them in Table 5 under Frequency on your answer sheet.

Exercise 1.4 Volume

Volume is a space that a given object occupies. The standard unit is **liter**. The most commonly used unit of volume are **liter (L, l)**, and **milliliter (mL, ml)** for liquid. 1 L = _____ mL = _____ μ L.

The volume or space equals length x width x depth. The unit is usually cubic meter (m^3). In our lab, volume is usually measured directly in liters or milliliters by using graduated cylinders and graduated pipets. Due to its surface tension, water forms a **meniscus**. The correct reading of any measurement is at the lowest level of the meniscus. Graduated beakers and Erlenmeyer flasks are not used for accurate measurement of volume instead one should use graduated cylinders.

A. The Use of Graduated Cylinder

Read the measurement as shown in the diagram below. _____ mL

B. Determine the Volume of a Penny

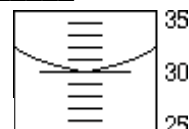

Figure 3 Graduate Cylinder Reading

- Put known volume water inside a graduate cylinder record the initial volume_____.
- Place the penny into the graduate cylinder slowly. Avoid causing splash. Record the final volume water._____
- The volume of your penny = Final water volume-initial water =_____ mL.

Exercise 1.5 Mass and Weight

Mass is the quantity of matter in a given object. The standard unit of weight is **gram (g)**. The commonly used units are **kilogram (kg)**, **gram (g)** and **milligram (mg)**. 1 kg = _____ g = _____ mg.

A. Please read the measurements as shown in the diagram below._____

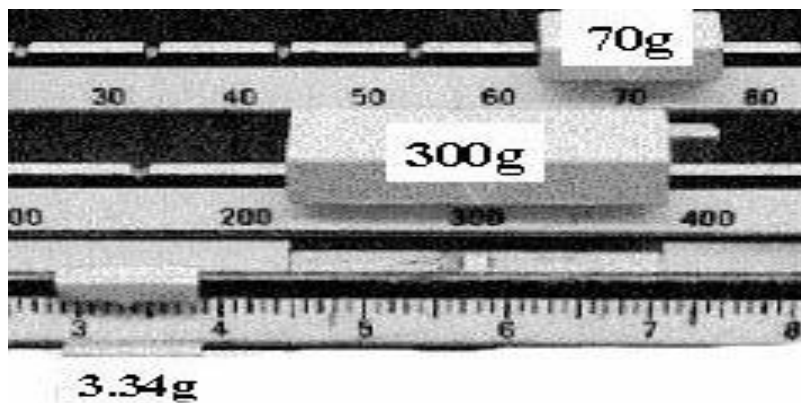

Figure 4 Triple Beam Balance Readings

Exercise 1.6 Temperature

The degree of hot and cold of an object is temperature. Thermometers are used to measure the temperature. In scientific world, the adopted unit is usually centigrade (Celsius, C). The conversion between Fahrenheit and Celsius is $^{\circ}\text{F} = (^{\circ}\text{C}) (9/5) + 32$; $^{\circ}\text{C} = (^{\circ}\text{F} - 32) (5/9)$.

- Read the temperature as shown in Figure 5 _____ $^{\circ}\text{C}$.
- If our body temperature is about 37°C , what would it be in _____ $^{\circ}\text{F}$?

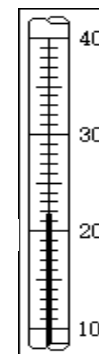

Figure 5 Temperature Reading

Exercise 1.7 Data Presentation and Interpretations

There are two major types of data presentation: table and figure or graph. For the same set of data, one only picks either a table or a figure to report results. For principles to use table and figure please read below (adopted and modified from L.E. Chinnery):

General Principles for Tables

- The table should be as simple as possible. Two or three small tables are preferable to a single large table containing many details or variables.
- The table should be self-explanatory. Therefore:
 - If codes, abbreviations, or symbols are used, these should be explained in the legend.
 - Each row and each column should be labeled concisely and clearly.
 - The specific units of measure for the data should be given.
 - The title should be clear, concise, and to the point. A good title will answer the
- Questions: What? Where? When?
 - Totals should be shown.
- Titles and legend
 - The title/legend of a table is placed above the body of the table.
 - The title is commonly separated from the body of the table by lines or spaces. If the table is small, vertical lines separating the columns are not necessary. [If you look at tables, in most journals you will find that there are no verticals at all].
- A series of tables should be numbered sequentially.
- If the data are not original, their source should be quoted.

General Principles for Graphs

A graph is a method of showing quantitative data (occasionally qualitative). When correctly drawn, it allows the reader to obtain rapidly an over-all grasp of the material presented. Whatever type of graph is employed, certain general principles apply.

- The simplest type of graph consistent with its purpose is the most effective. No more lines or symbols should be used in a single graph than the eye can easily follow.
- Every graph should be completely self-explanatory. Therefore, it should be correctly labeled as to title, source, scales, and explanatory keys or legends.
- The title/legend for a graph should be self-explanatory and placed below the figure. The titles should include the X and Y axis and the title of the graph.
- When more than one variable is shown on a graph, each should be clearly differentiated within the legend (or a key used).
- No more co-ordinate lines should be shown than are necessary to guide the eye.
- The independent variable is plotted on the horizontal axis and the dependent variable on the vertical (or with classified data - the frequency is represented on the vertical axis and the method of classification on the horizontal).
- On an arithmetical scale, equal increments on the scale must represent equal numerical units.

- Scale divisions should be clearly indicated as well as the units into which the scale is divided.
- Numerical scales should normally start with zero. If this is not sensible the departure from practice should be clearly indicated.
- If a line is drawn to represent the relationship between two variables, the original data points should be presented.
- A series of graphs should be numbered sequentially along with any other figures. This numbering will reflect the order in which they are presented in the text.
- The following table lists the graphs commonly used to represent different types of data.

Type of Data	Nature of Variable	Type of Diagram
Frequency Distributions	Qualitative	Bar Pie Pictogram
	Quantitative Discrete	Bar Pie Pictogram
	Quantitative Continuous	Histogram Frequency Polygon Frequency Curve
Trend (e.g. change with time, age, substrate conc.)	Quantitative	Scatter Line Semi Log Log Log

Examples of these graphs can be accessed at
<http://scitec.uwichill.edu.bb/bcs/courses/Biology/BL20B/Cond&Pres.htm>

References:

1. Campbell, N and Reece J 2005 *Biology.7th* Pearson
2. Dolphin, Warren D 2002 *Biological Investigations Form, Function, Diversity and Process.*6th McGraw Hill
3. Dissecting tool pictures are from Ted Pella, In: <http://www.tedpella.com/>
4. L. E. Chinnery 1999. BL 20B - Biological Data Analysis Condensation and Presentation of Data
<http://scitec.uwichill.edu.bb/bcs/courses/Biology/BL20B/Cond&Pres.htm>

Lab 1 Answer sheet

Name _____

Show your complete lab to your instructor and turn in pages 11 -13 only.

Exercise 1.7 Data collection and Analysis

2. Data presentation

Normally, you either use table or figure to present data. Here we are practicing making table and figure therefore we use both forms to present the same data.

Table 5 Frequency of the Range of Height in Biology 7 Class

Range of Height	Frequency (total number in each category)	Average Length of Index Finger (cm)
Short		
Medium		
Tall		

3. Plot the graphs below. For Each graph include title of the graph, titles of X and Yaxis, and units. Use the data from Table 1.5 above to plot graphs. A sample table (Table 1.6) and graph (Figure 1.6) is shown below.

Table 6 Sample Table

Height Categories	Frequency
short	5
medium	8
tall	7

Figure 6 Height Distributions in Biology 7 class.

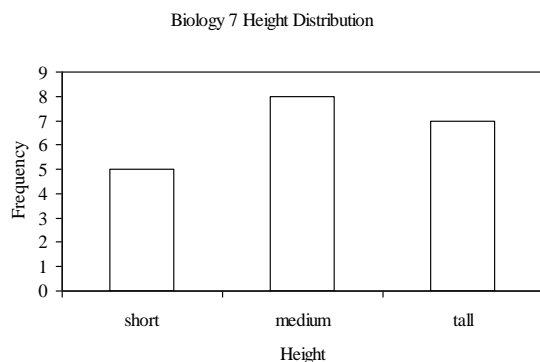

Results

1. Data presentation.

- a. Plot a graph related to the average length of index finger of Biology 7 and height categories (short, medium and tall). **Independent variables** (defined as factors that can be varied or manipulated in an experiment)

such as temperature, time and height categories) (x –axis) are _____.
The **dependent variables** (defined as your measurements) (Y-axis) are _____.



Figure 7 _____

b. Plot a graph related to height categories and frequency. Independent variables (x –axis) are _____. The dependent variables (Y-axis) are _____.

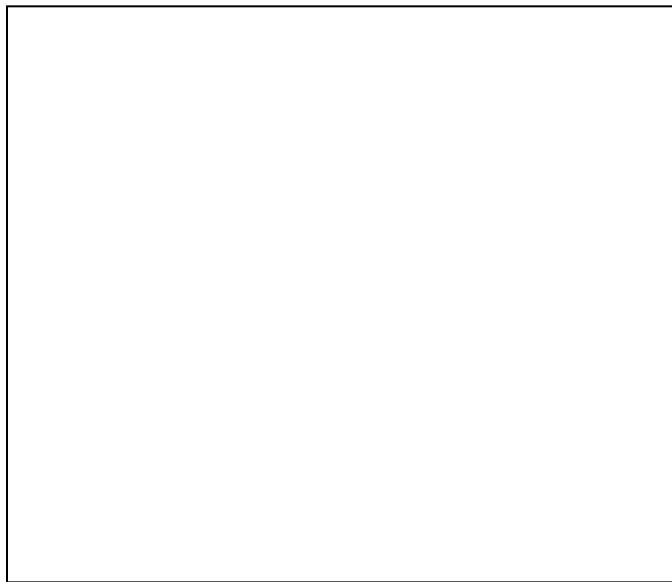

Figure 8 _____

Use words to report your results:

Figure 7 shows that the average index finger lengths for short, medium height and tall people were _____, _____, and _____ individually. There _____ a _____ relationship between height and the length of an individual's index finger. Figure 8 indicates that the most common height of the class was _____. The least common height of the class was _____.

Lab 2 Prep Lab Questions

1. List two types of scopes that will be used in lab 2 and their uses.

Microscope Types Used in Lab 2	Functions

2. Finish the labels (Use figure 1b of Photo Atlas for Biology to complete the labels).

- a. _____
- b. _____
- c. _____
- d. _____
- e. _____

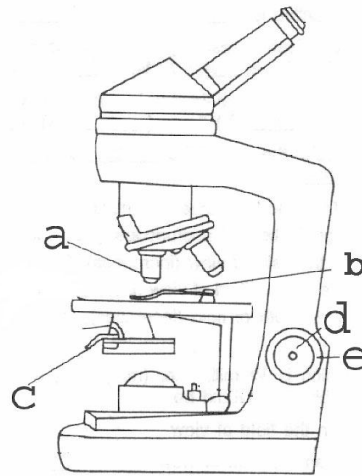

Figure 1.9 Microscope

Lab 2 Microscope and Cell

Name _____ Microscope Quiz (5 pts) _____

Pre-lab Readings:

1. Reece et.al. 2011 *Biology* Chapter 6.
2. Perry and Morton (1996) *Photo Atlas for the Biology* Pages 1-4, 17 and 70
Wadsworth Publishing Company

Objectives

1. To learn the use of compound microscope and stereo microscope.
2. To learn the basic structure of prokaryotes, plants and animals.
3. To learn wet mount technique.

The microscope is designed to make small objects visible to human eyes. Early in the seventeenth century, Galileo Galilei arranged two lenses inside a cylinder. He happened to look at an insect and later described the eyes of the insect. He became the first person to record a biological observation through a microscope as a non-biologist.

In the mid-1600s, Robert Hook used his primitive microscope to observe the thinly sliced cork from a mature tree. He saw many tiny compartments and named them the Latin name *cellulae*, meaning small rooms. Microscopes have been a popular and important tool for Biologists since its invention. There are three basic types of microscopes: compound microscope, stereoscopic microscope and electron microscope. In this lab, we will learn to the proper techniques of using the compound and stereoscopic microscopes.

Exercise 2.1 The Components of a Microscope

Introduction

The microscopes common used in our lab are compound binocular or monocular compound light microscopes. Binocular microscopes have two eyepieces. Monocular microscopes have one eyepiece. A specimen is viewed through a series of lenses therefore they are called **compound microscope**. These microscopes require the transmitting of light through the specimen. So the samples have to be thin. They are used to observe minute specimens. The highest magnification can go up to 1000 x. These microscopes are made **parfocal**. When one objective is adjusted in focus, little refocusing is required when it is moved to another lens. In this exercise, you will learn the basic parts of the microscope and how to use a microscope correctly.

Materials

compound microscope

Procedure

- A. Obtain a light microscope. The correct way of carrying it is to use one hand support the base and the other hand hold the arm.



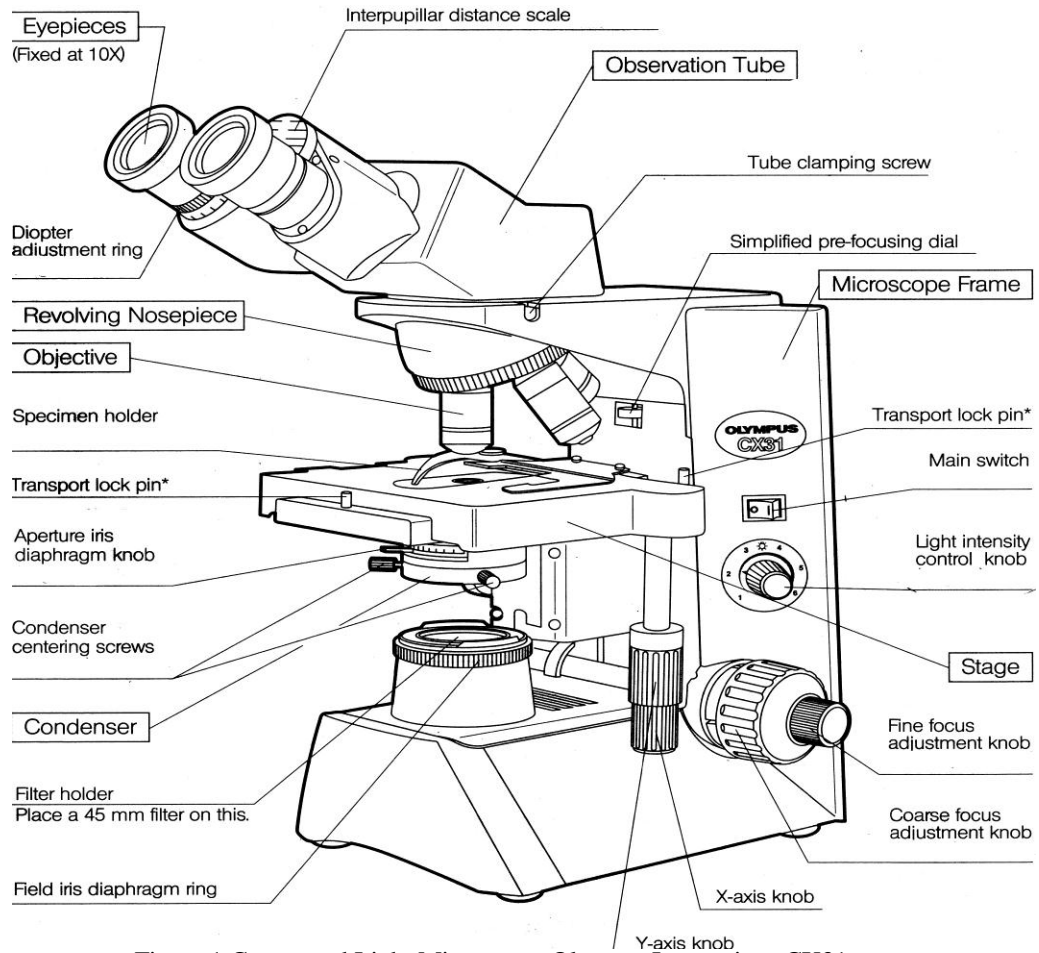

Figure 1 Compound Light Microscope Olympus Instructions CX31

B. Read the following descriptions to find the parts and functions of each important part of your microscope as shown in Figure 1.

1. The **eyepieces or oculars** have a fix magnification of 10 (10X= 10 times larger). A **pointer** (a black line) is usually placed in the eyepiece. It is used to point to the object inside of the view.
2. **Objectives** are used to further magnify objects. **Use the resolving nosepiece to change the lens.** Use Figure 3d-e and your own microscope answer the following questions. Based on the length of the objective from the shortest to the longest. Fill in the magnification numbers for each:

- i. The shortest lens called scanning lens is ____X.
- ii. The second shortest (low objective) is ____X
- iii. The third shortest (high objective) is ____X.
- iv. The longest lens is ____X. It is used with immersion oil. Please do not use the oil lens unless you are told so.
- v. Complete the labels of this objective.



3. The **stage** provides support for a slide. The slide can be held by specimen holder. Two stage adjustment knobs (**X axis** and **Y axis**) control the movement of the slide along the two axes.
 - i. Which axis allows you to move the slide from front to back? ____
 - ii. Which axis allows you to move the slide from the left to the right? _____
4. The **coarse and fine focus adjustment knobs** change the distance from the lens and the stage. They are used to focus the specimen on the slide. The coarse focus adjustment knob is used with 4x and 10 x objectives. The fine focus adjustment knob is used for minute movement and it is **ONLY** used with 40x and oil immersion lens.
5. The **condenser lens** is to concentrate and direct the light. In some microscope, there is an **adjust knob** to control the height of the condenser.
6. The **field iris diaphragm** and the **light intensity control knob** change the amount of light passing through the specimen. Both can be used to adjust the brightness of the view. Normally, one should select a light level to make one's eyes feel comfortable. An extremely bright light will hinder your ability to see due to the lack of contrast in your view.

Exercise 2.2 Basic Microscope Techniques

Introduction

Use of a microscope is not very difficult. Here are several things you need to know:

- **Use only lens paper to clean the lens.** If the lens paper is not helping you too much, please inform your instructor.
- Please do not try to remove any microscope parts. Necessary repairs or cleaning can only be done by a trained technician.
- The scanning objective (4X) is in position both at the beginning and the end of the lab before the microscope is returned to its storage cabinet.
- Clean the stage to prevent rust and corrosion of the microscope.
- Keep the microscope inside the cabinet when you finish using it. Wrap the cord around the microscope observation tube for a few times.
- Some of the microscopes may not be working very well. If that happens to you, please inform your instructor.

Materials

Prepared slides:	Letter "e" or other letter, Cross colored threads or fibers
Others:	lens paper, rulers

Procedures

A. . The Total Magnification

Microscopes are used to magnify minute the structures that we cannot see with our naked eyes. The **total magnification** equals to the product magnification of the eyepiece and objective. Complete the total magnification in Table 1

Table 1 Calculation of the Total Magnification

<i>Objectives</i>	<i>Ocular Lens</i>	<i>Objective Lens</i>	<i>Total Magnification</i>
Scanning	10	4X	10 x 4X =
Low power	10	10X	
High power	10	40X	
Oil immersion	10	100X	

Figure 4b of your Photo Atlas for Biology shows a picture of cork cell. The label list it as 100x. If the ocular lens is 10X, which objective lens did it use to view the cork cells? ___X. What does 100x mean? _____ (Hint: we use microscope to magnify).

B. Field of View

- The light circle you see through the microscope eyepieces is called the **field of view**. The larger the field of view, the easier you will be able to locate your specimen.
- Based on Figure 2,
 - if you are trying to locate a specimen fast, which objective should you use initially? ___
 - which objective transmits the most amount of light? _____

Figure 2 The Field of View (Apertures of the Lens)

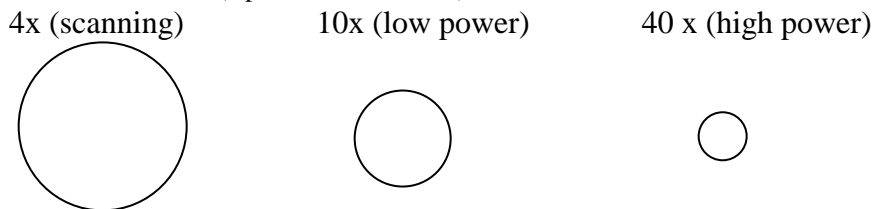

C. The Working Distance

- The distance between the stage and the objective lens (when the specimen is in focus) is called the **working distance**. This distance indicates the room for people to work under certain objective. As illustrated in Figure 3, which objective has the smallest working distance? _____
- Why shouldn't you replace the slide under 40X objective?

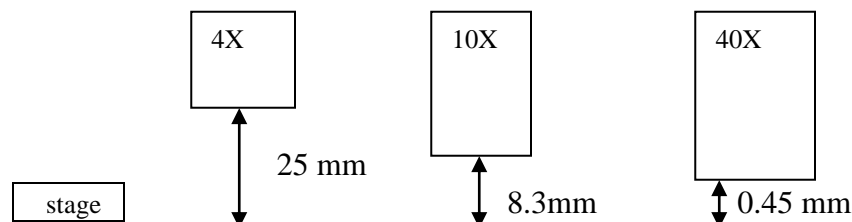
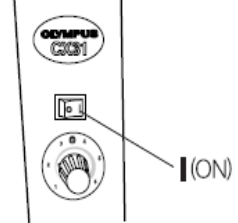
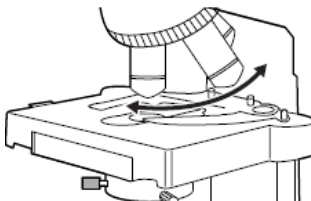
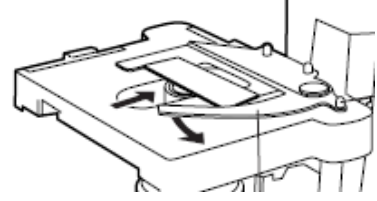

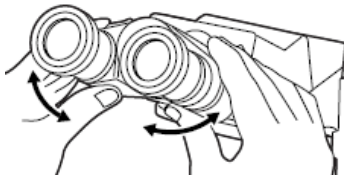
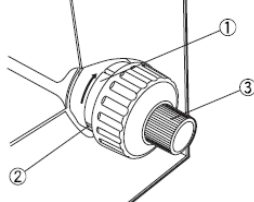
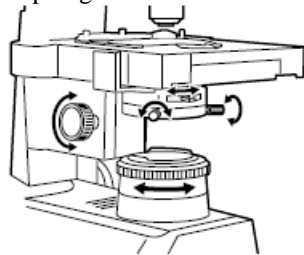
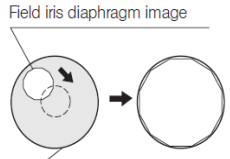
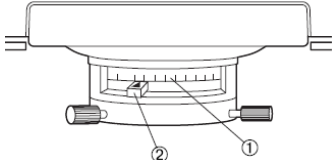

Figure 3 Working Distance

D. Quick Procedures to Use a Microscope (Letter e Slide as an example)

<p>1. Plug the microscope into the outlet and turn on the power.</p> 	<p>2. Rotate the 4 X lens into position (you should hear the sound of click) by using the resolving nosepiece</p> 	<p>3. Place the slide on the stage and move "e" into the light path by using X-axis and Y-axis knob.</p> 
<p>4. Use the coarse adjustment knob to raise the stage up until it stops.</p> 	<p>5. Adjust the interpupillary distance.</p> 	<p>6. Use the focus adjustment knobs (1) and (3) to focus on specimen under the microscope.</p> 
<p>7. Center the field iris diaphragm.</p>  <p>Field iris diaphragm image</p>  <p>Field of view through eyepieces</p>	<p>8. Adjust the brightness of the field by aligning the aperture iris diaphragm knob (2) with the numerical aperture (NA) number (1) engraved on the objective.</p>  <p>10. Focus and center letter e in the field of view and switch directly to 40 X objective. Use only fine adjustment knob to focus.</p>	<p>9. When letter e is centered and focus in the field of the view. Switch to 10X objective for more magnification. Use adjustment knobs to focus on letter e.</p> <p>11. After you finish your observation of the slide, return the objective to 4x, remove the slide from the stage and observe the "Cross color fibers or threads slide."</p>

Answer the following questions for Letter e slide

12. When the letter "e" is in focus, move the stage adjustment knob. To which direction of "e" move, if you move the slide to the right and up? _____ and _____

e

Letter e on stage without seeing through microscope

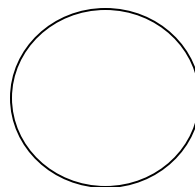

Letter e under 4X objective

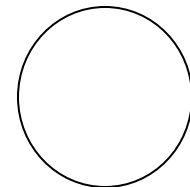

Letter e under 10X objective

E. How to adjust the brightness of the field?

1. Look through the eyepiece, and close the iris diaphragm. What happens to the brightness of the field?

2. Now open the iris diaphragm. What do you observe?

E. The Depth of the Field

The **depth of the field** is the thickness of the specimen that may be in focus at one time. In this exercise, you will use a slide that has three different color threads laid on top of each other. This provides a depth of the field of three-threads thick. The objective that has the greatest depth of field will allow you to see all three threads clearly at one time.

1. Focus and locate the cross of the threads. How many of them in focus at the same time under 4X? ___
2. Observe the cross of the threads under 10 X and 40X.
 - a. How many threads in focus at the same time under 10X objective?

 - b. How many threads in focus at the same time under 40X objective?

Which of the objective has a shortest depth of field (You can only see one thread in focus at one time)? _____

Exercise 2.3 Microscope Slides and Drawings

A. Prepared Slides

- Prepared slides are commercially manufactured slides that contain the specimen that being permanent preserved. It normally has a label that contain the company's name, specimen name, catalog number and one of the following terms:
 - **c.s or x.s.** means cross section. Cross section is a transverse section of a structure.
 - **l.s.** means longitudinal section.
 - **w.m.** means whole body mount.

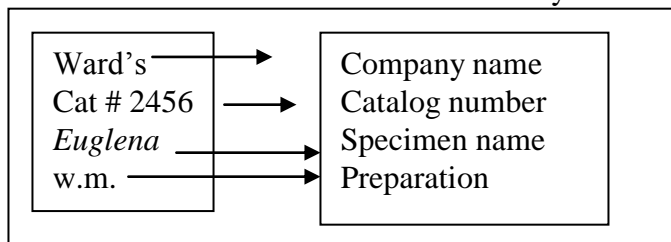

Figure 4 A Prepared Slide

B. Blank Slides

- Regular **blank slides** are used for observing all cultures with **cover slips** on

- Well or **concavity slide or depression slides** are used for observing live culture without cover slips under low objectives.



Figure 5 A Blank Slide and a Cover Slip

C. Some Rules for Biological Drawing

- Draw your sketch with a pencil.
- Draw your sketch in the center of a page or provided space.
- Only draw the structures that you observe. Not the structures that you think they should be there.
- Label the structures with horizontal lines only. Do not cross lines.
- Label the name of organism with printed letter.
- Indicate the total magnification of the sketch.

Exercise 2.4 Preparation of a Wet Mount

Introduction

To observe live specimen you need to learn to prepare a wet-mount slide that is to

- A. use water to prevent the materials from drying out. *Elodea* is an aquatic plant.

Materials

compound microscope
 clean blank slides and cover slips
 living *Elodea* (*Anacharis*)
 water and eyedropper
 dissecting needle

Procedure

- B. Obtain a slide box. Record the box number
- C. Take a clean slide out.
- D. Place a drop of water in the center of a clean microscope slide.
- E. Remove a single leaf of *Elodea* and place it in the drop of water.
- F. Use a dissecting needle and place a cover slip at a 45° angle above the slide with one edge of the cover slip contact the edge of water droplet and slowly place cover slip on the slide.
- G. Use a piece of tissue to remove the excess amount of water.

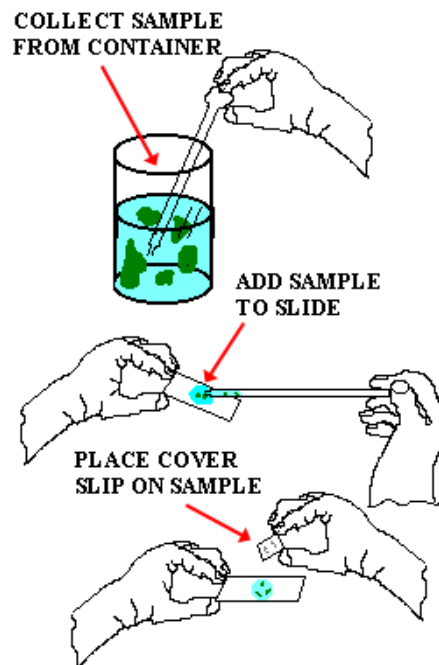
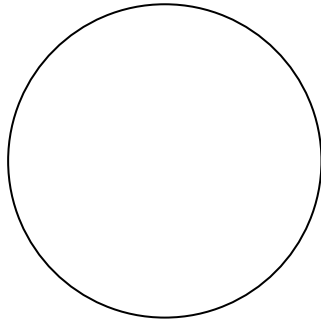
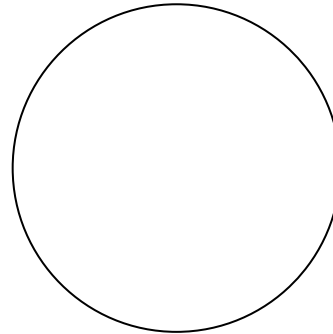

Figure 6 How to Make a Wet Mount

- H. Observe it under 10X objective and 40X objective. (Figure 70a, *Photo Atlas for Biology*).
- I. Draw **one** cell diagram in space provided below. **Label plant cell wall, cytoplasm and chloroplasts for 400X total magnification.**
- J. Save the slide for your next exercise.



Elodea 100X (total magnification)



Elodea 400x

Exercise 2.5 The Stereoscopic Microscope

Introduction

The stereoscopic (dissecting) microscope has relative lower magnification than the light compound microscope. It is used to observe larger and thicker specimen which may not allow light to travel through. The stereoscopic microscope has the larger depth of field.

Materials

- stereoscopic microscope
- Elodea* wet mount slide

Procedure

- A. Remove your dissecting microscope from the storage cabinet and locate the parts: binocular head, eyepiece, focusing knob, magnification, changing knob and illuminator in Figure 7.
- B. Place the prepared

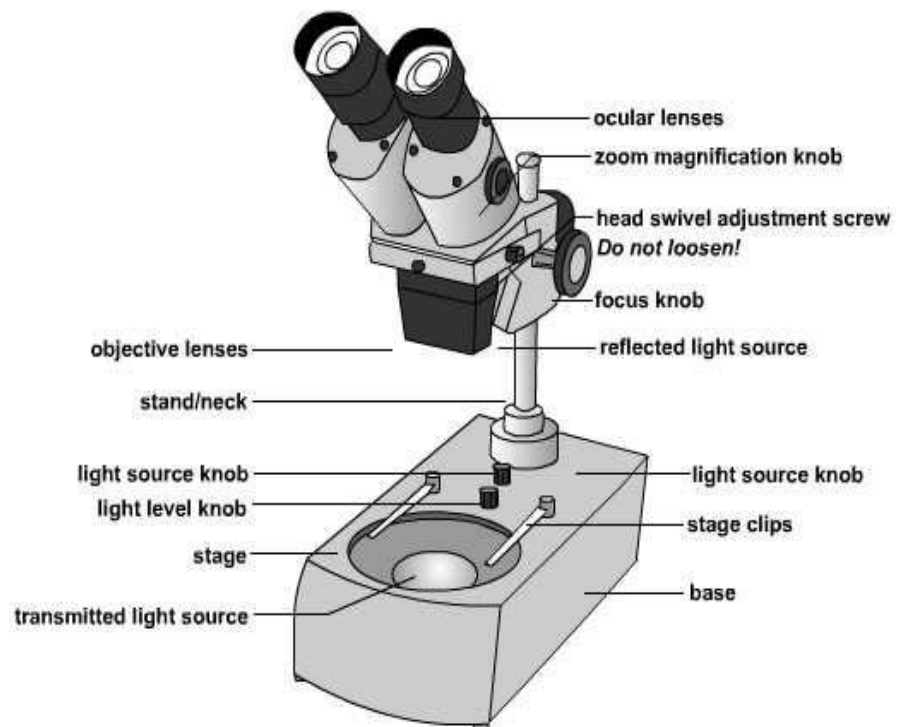

Figure 7 Dissecting microscope

Elodea wet mount slide from Ex. 2. 4 under the scope and observe the structure under the dissecting microscope.

Can you see the cells? _____

Can you see chloroplasts? _____

C. Put your hand under the dissecting microscope, adjust the focus knob, can you see your fingers clearly?

D. How do you adjust the magnification of the dissecting microscope?

E. How are dissecting and compound microscopes different?

F. Clean the slides and cover slips, and place them in your slide box.

G. Store the dissecting microscope back to the cart.

Exercise 2.6 Types of cells

According to the cell theory, all organisms consist of cells or the product of cells, or are single cells themselves. In this exercise, we will review the use of microscope and study different types of cells. We will compare unicellular and multicellular cells; prokaryotic and eukaryotic cells; plant and animal cells.

Materials

Supplies:

compound microscope,	clean slides
cover slips	forceps
dissecting needles	lens paper
detain	immersion oil
diodine	clean toothpicks

Prepared slide:

Gram-stain of mixed cocci, bacilli and spirilla

A. Prokaryotes include the simplest cellular organization. Inside prokaryotic cells, there are no true nuclei or organized organelles. Many prokaryotic cells consist of an outer cell wall. Outside the cell wall is a sheath. Some cells form a colony, the sheath will surround the colony as a whole. Inside the cell wall is the plasma membrane. Plasma membrane sometimes is also called cell membrane. Plasma membrane is not very easy to be distinguished under the microscope. The mass of cytoplasm makes up the rest of living mass or protoplast inside a cell.

Procedure

1. Obtain a prepared slide of bacteria and observe it under the microscope. These bacteria are usually very small. So if you cannot see well under 40 X objective, you may use oil lens.

- To use oil objective, you need to have the specimen in focus under high power objective and then rotate your 40 X half way, add one drop of immersion oil on the top of the slide and then rotate the oil lens in position. Only use fine adjustment knob to adjust the focus. Use paper to wipe out oil after observation. Also use lens papers clean all lenses.
- There are three major shapes of bacteria: *coccus* (ball shape), *bacillus* (rod shape), and *spirillum* (helical). Find the prepared slides and observe the different bacteria (Figure 17 c & d *Photo Atlas for Biology*). **Draw a diagram of each type bacteria under the oil immersion objective.**

Coccus 1000X

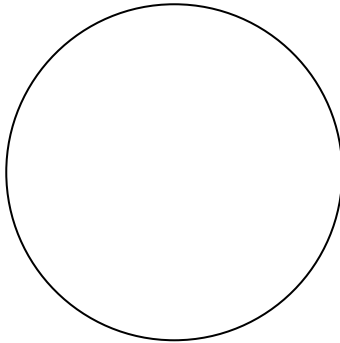

Bacilli 1000X

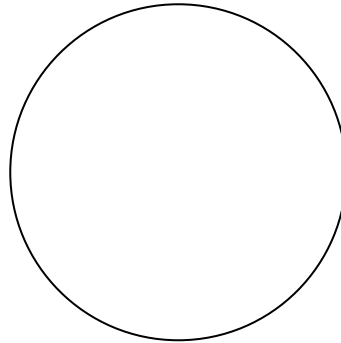

Spirillum 1000 X

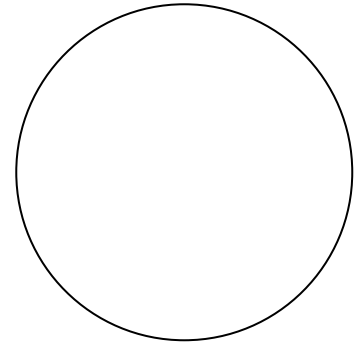

B. Eukaryotes

Eukaryotic cells have nuclei and membrane bound organelles. They are larger in size than prokaryotic cells.

Procedure

1. Animal cells

Members of the Kingdom Animal are usually multicellular and heterotrophic eukaryotes. Animals usually do not have cell walls nor chloroplasts or central vacuoles. In this exercise, you will observe human cheek cells (*Squamous epithelium*).

- Scrape the inside of your cheek gently with a clean toothpick to remove some cheek cells (NO blood cells).
- Smear the cells on a clean slide add a drop of concentrate iodine solution.
- Cover with a cover slip and observe under the microscope (Figure 17e *Photo Atlas for Biology*)
- Discard the used tooth picks and slides into Biohazard bag.**
- Draw two human cheek cells.**
- Label cell membrane, nucleus and cytoplasm.**
- Do you see any bacteria on your cells? _____

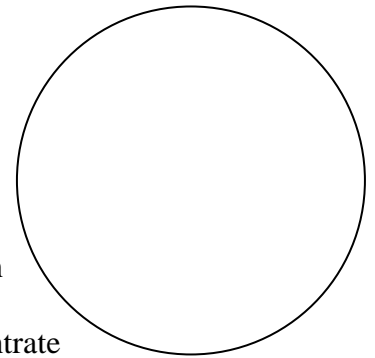

Squamous epithelium (400X)

To store your microscope:

- Rotate the 4X or 10 X objectives into position.
- Remove the slide from the stage.
- Clean the stage if it is dirty.



- d. Turn off the power, and unplug the cord and wrap it around the microscope observation tube a few times.
- e. Return the scope to the cabinet using both of your hands.

Assigned Microscope

You will use the same microscope in this class for this semester. Write down your microscope number _____. You will use the same slide box to hold your blank slides for your group. Write down your number here _____

Self Quiz

1. If a picture of a slide is labeled as w.m. 100X, explain the meaning:

2. Identify the parts of a microscope.

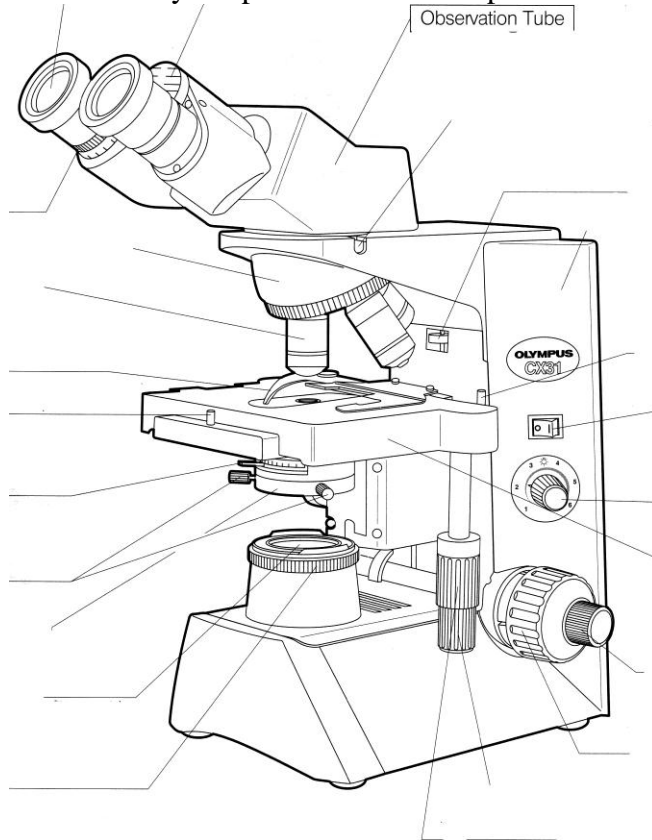

References

Microscope diagram <http://comp.uark.edu/~karbuck/micro.html>

Lab 2 Answer Sheet

1. With the increase of magnification,
 - 1) the working distance of a microscope _____(increases/decreases/remains the same);
 - 2) the field of view _____(increases/decreases/remains the same);
 - 3) the depth of a field _____(increases/decreases/remains the same).

2. Which of the objective is the longest? _____
3. Which of scope needs the light to pass through the specimen in order to be viewed? _____
4. What word is used to indicate that if one objective is in focus, other objectives should also be in focus? _____
5. Which objective transmits the least amount of light? _____
6. What is the function of iris diaphragm? _____
7. Which of the adjustment knobs (coarse/fine) is used for approximate focus?
8. Which of the adjustment knobs (coarse/fine) is never used on high power?
9. Unicellular means _____ cell (s).

8) Comparison of plant and animal cells

<i>Cell type</i>	<i>Example observed in today's lab</i>	<i>Unique structure present (from your text book)</i>
Plant		
Animal		

Lab 3 Pre-lab Questions

1. Define microevolution.

2. List the mechanisms of microevolution.

Lab 3 Evolution and Systematics

Pre-lab Reading

1. Reece et.al (2011) *Biology* Chapters 23 and 26

Objectives

1. To learn the Hardy-Weinberg theorem.
2. To study microevolution and the mechanism of microevolution in a simplified game.
3. To understand allele, allele frequency, and gene pool.
4. To be able to calculate allele frequency.
5. To learn the concept of systematics.
6. To learn how to classify living organisms.
7. To learn to use a key and try to construct one.

Evolution can be defined as the genetic changes through time. The smallest unit of evolution takes place at the population level. Individuals do not evolve. The sum total of all the alleles of a population is called the **gene pool**. There are two types of evolutions. If evolution occurs within a gene pool, it is called **microevolution**. If it happens above the species level, it is called **macroevolution**. In this lab, we will investigate microevolution and its mechanisms including **mutations, natural selection, and genetic drift and gene flow**.

The **Hardy-Weinberg theorem** describes the gene pool which is NOT evolving. This theorem was developed by two mathematicians G. H. Hardy and G. Weinberg independently in 1908. The theorem states that the genetic frequencies remain constant from one generation to another. A non-evolving population is said to be in **Hardy-Weinberg equilibrium**. There are conditions that contribute to neither Hardy-Weinberg equilibrium such as a large population size, random mating, no mutation, gene flow nor natural selection (Reece et.al. 2011). Mathematically, the Hardy-Weinberg equilibrium may also be expressed as: $p^2 + 2pq + q^2 = 1$. Where p = the frequency of allele A, and q = the frequency of allele a. $p + q = 1$. This mathematic formula can be used to calculate or predict **allele frequencies** (proportion of allele in a population) within a population.

Materials

Cards: 40 A 40 a 6 α

Prelab

- Every one will receive two cards of one genotype of any trait. Each card represents one allele. Explain why do you have two cards?
_____.
- **Your initial genotype is** _____.
- If we have a student population of 36 people in our class with two alleles A and a, the breakdown of genotypes are : 12 AA, 12 Aa and 12 aa . The allele frequency for A = $(AA+Aa)/72$.
 $A = (12 \times 2 + 12)/72 = 0.5$, a = _____.

- Get one of the utensils based on your genotype. AA = fork, Aa = forceps aa = spoon for Exercise 3.4.

Exercise 3.1 Simulation of Random Mating

Random mating is the members of certain gene pool of a population mate by chance.

Procedure

- A. Everyone places your cards (your alleles in a box) to make a gene pool.
- B. We will shake the box. Each person will draw two cards from the box randomly.
- C. Record your genotype for F₁ generation on the board.
- D. Return your cards to box.
- E. We will shake the box again so the next student will pick two cards out.
- F. Record genotypes on board.
- G. The mating will stop when the last student finishes pick up cards.
- H. Complete Table 3.1.

Table 3.1 Random Mating

P Generation		F ₁ Generation (New Generation)				
Allelic Frequency		Genotypic Number tally			Allelic Frequency	
A = 0.5	a = 0.5	AA=	Aa=	aa=	A =	a =

Exercise 3.2 Genetic Drift and Bottle Necking

Genetic drift is the fluctuation of allele frequency from one generation to the next. A sudden change in environment such as natural disaster can cause bottleneck effects, where the new gene pool no longer represents the original gene pool.

Procedure

- A. Return your cards to your original type.
- B. In this exercise people with AA did not survive Hurricane Katrina. Therefore they can not mate.
- C. The rest people will put your genes in class gene pool.
- D. These people will mate by picking out two cards.
- E. Record the genotype on board.
- F. Fill in the blanks in Table 3.2.

Table 3.2 Bottleneck Effect

P Generation		F ₁ Generation (New Generation)				
Allelic Frequency		Genotypic number			Allelic Frequency	
A = 0.5	a = 0.5	AA=	Aa=	aa=	A =	a =

Exercise 3.3 Mutation

Mutation is the change of DNA sequence. Mutation is a rare event. It generates new genetic information. In this exercise, we will simulate the mutation of three “A” cards and three “a” cards to “α” cards.

Procedure

- A. The instructor will replace some cards with mutated cards: α .
- B. Everyone draw two cards out and return them back to the box.
- C. Record the genotypes on board.
- D. Fill in the blanks in Table 3.3.

Table 3.3 Mutation

P Generation		F₁ Generation (New Generation)								
Allelic Frequency		Genotypic Number Tally						Allelic Frequency		
A = 0.5	a = 0.5	AA=	A α =	Aa=	$\alpha\alpha$ =	aa=	a α =	A =	a =	α =

Exercise 3.4 Simulations of Natural Selection-Predator and Prey

There are variations within a population. Individuals in a population react to the environmental changes differently. In addition, they compete for food, reproduction and survival. Overall the **fittest species** will have reproductive success in population. Natural selection is the differential reproductive success. It enables a population to adapt to its living environment. It normally occurs longer than one generation. In this exercise, for the simplicity, we will only do two generations of simulation. We will conduct a predator and prey simulation. You will play the predatory bird. Your preys are two types of beads.

Materials

For each group:

- 40 red beads
- 6 spoons
- 6 paper cups
- 6 forks
- 6 forceps
- 1 weighing dish to hold beads

Procedure

- A. Everyone exchange your cards and return to your INITIAL genotype.
- B. Work as a small population of six with two forks (AA); two forceps (Aa) and two spoons (aa). See Table 3.4.
- C. P Generation Feeding
 1. For each group count out 20 red beads and 20 white beads. Place them in a white weighing dish.
 2. You will use your feeding tools to take the beads out from the box, and place them into your cup (consumed).
 3. Each person will feed as much as and as fast as possible. The feeding will last for about 5 seconds.
 4. Record the number of beads in your cup in Table 3.4.

Table 3.4 Consumed Prey of P Generation

Feeding tool	Initial Genotype	Number of Consumed Red Beads
Fork bird 1	AA	
Forceps bird 1	Aa	

Feeding tool	Initial Genotype	Number of Consumed Red Beads
Spoon bird 1	aa	
Fork bird 2	AA	
Forceps bird 2	Aa	
Spoon bird 2	aa	

- Which predator was the most successful one? _____
- Are there variations among predators with the same feeding tools? _____
- Which prey was the more successful one? _____
- The individual obtained the least amount of food was too hungry to mate.
- The rest of group members will return their genes to the class gene pool and mate.

Table 3.5 Natural Selection

P Generation		F ₁ Generation (New Generation)				
Allelic Frequency		Genotypic number			Allelic Frequency	
A = 0.5	a = 0.5	AA=	Aa=	aa=	A =	a =

Exercise 3.5 Biochemical Evidence for Evolution Relationship

The development of the theory of evolution is the core of modern Biology. There are many evidences in Biology to support the theory of evolution. These evidences include morphological evidences, fossil evidences, embryological evidences and biochemical evidences.

In this exercise, we will test the similarity of blood proteins between one species and another by using the Nutall Precipitation technique. The Nutall Precipitation technique capitalizes on the vertebrates' immune response. When foreign materials (antigens) are introduced into an animal's blood stream, the vertebrates will develop antibodies against these foreign molecules. These antibodies remain in animal's blood serum. Serum (plural sera) is the clear or yellowish liquid that remains after the blood cells have been removed. Should the same antigens infect the animals again; the antibodies will agglutinate to these antigens therefore form some precipitation. In Nutall Precipitation, a rabbit is injected with human serum. Rabbit will produce antibodies again the foreign human serum. The human antiserum is extracted and used to test against other animal serums. By judging the degree of agglutination amounts, we can determine the degree of relatedness of human and these animals. Animals that are more closely related to human will cause a greater degree of agglutination than the animal species that are less related to human.

The purpose of this exercise is to test the relatedness of various animals to human by using **Nutall precipitation technique**. We will make serial dilutions (repeated dilutions) of each animal serum. We will mix human antiserum with these animals' sera dilutions. A stronger reaction will occur at a greater dilution factor. The degree of agglutination can be observed either by naked eyes or by using dissecting scopes. The results are used to establish the relatedness of human to these animals.

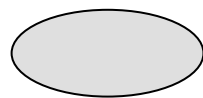

Agglutination

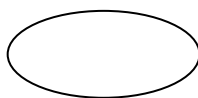

Not Agglutination

Figure 1 Comparison of Agglutination and none Agglutination Reaction under the dissecting scopes

Hypothesis

Form a hypothesis based on the morphological knowledge. Arrange the four animals (cow, chimpanzee, frog and monkey by its relatedness of human (from the most closely related to the least) on the space provided.

Predications

Based on your hypothesis above, predict the degree of agglutination of various animals' sera against human antiserum. Use one + for slight reaction and ++++ for very heavy reaction. Fill in the blanks below.

Serum	Degree of Agglutination against Human Antiserum
Cow	
Monkey	
Chimpanzee	
Frog	

Questions:

1. If you are testing the relatedness of human and cow, you should use cow serum against _____ antiserum.
2. If you are testing the relatedness of chimpanzee and human, you should use chimpanzee serum against _____ antiserum.

Materials

For each group:

5 Testing well trays

10 Stirring picks

1 water bottle with dropper

1 vial simulated human antiserum

3 plastic droppers

Common Materials

1 vial of simulated human serum

1 vial of simulated chimpanzee serum

1 vial of simulated frog serum

1 vial of simulated cow serum

1 vial of simulated monkey serum

Procedure

- A. Take five test trays and label them as "Human Serum, Cow Serum, Chimpanzee Serum, Frog Serum and Monkey Serum" individually.
- B. Start with "Human Serum" test tray. Label the first eight well 1 through 8 as shown in Figure 3.2

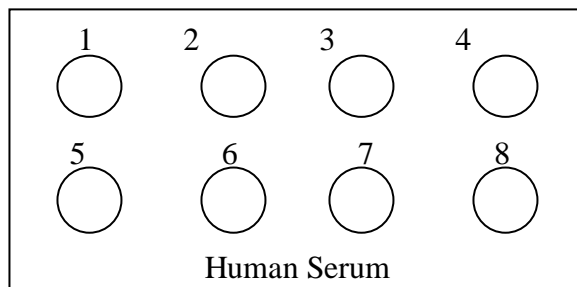

Figure 2 Test Tray of Human Serum

- C. In each well on “Human Serum” test tray, place the appropriate human serum and dilute with water as directed in Table 4.1. Use the stir picks mixing each well starting from the most diluted solution to the least diluted solution (well 1 through well 8). Clean off the stir stick after each mixing to avoid changing the concentration of solutions.

Table 3.6 Dilution for Wells 1 through 8

Well Number	Drops of Serum*	+ Drops of Water
1	1	7
2	2	6
3	3	5
4	4	4
5	5	3
6	6	2
7	7	1
8	8	0

- D. Now place 8 drops of Human Antiserum in each well and mix thoroughly. (Be sure to clean off the stir picks after mixing each well).
- E. Watch for two minutes for reactions in each well. Record the degree of agglutination and time of reaction. Occasionally stirring will help you to see the precipitation reaction. You may also place your tray under stereoscopic scope to observe the results of the reaction. Agglutination occurred after two minutes shall be ignored for the purpose of this test.
- F. Record your results in the data table on your answer sheet.
- G. Repeat for the rest of animal (cow, chimpanzee, frog and monkey) sera.

*Notes: if you are using the cow serum test tray, you should use cow serum for well number 1-8. If you are using chimpanzee serum test tray, you should dilute chimpanzee serum etc. Use Human Antiserum for all tests.

Reference

Part of this lab is modified after Dave Robinson, Iowa State University

Lab 3 Answer Sheet

Name _____

Table 3.6 Summary of Allele Frequencies for all Simulations

		Allele Frequency		Any Change?	Cause of the change if the frequency changed
		A	a	Yes or No	
P	Generation	0.5			
F1	Random Mating				
	Bottleneck				
	Mutation				
	Natural Selection				

Exercise 3.4 Simulation of Natural Selection

1. With in your small population of six, are there genetics variations? _____
2. If people use the same feeding tools, how come they do not consume the same amount of prey?

Summary Question

If these allelic frequencies keep on changing from one generation to the next, eventually, what would it trigger?

Exercise 3.5 Biochemical Evidence for Evolution Relationship Use number of “+” to **predict** the degree of agglutination. The heaviest reaction = +++++.

Serum	Degree of Agglutination against Human Antiserum
Human	
Cow	
Frog	

1. Data Table

Table 3.5 Nutall Precipitation (+++ Heavy Agglutination (immediate and strong reaction), ++ medium Agglutination (Precipitation occurs after a few moments.), + slight Agglutination (It takes some time to form a few precipitates.) - No reaction

Organisms	Well Number							
	1	2	3	4	5	6	7	8
Human								
Cow								
Chimpanzee								
Frog								
Monkey								

2. Construct an evolutionary tree (any type) of human, cow, frog, chimpanzee and monkey based on your test results.

3. Why do we perform the test on human serum instead of rabbit serum?

4. If you want establish the relationship of cow with pig and sheep what kind of serum and antiserum should you use?

Lab 4 Prokaryotes Pre-lab Questions

1. What is gram stain?

2. The shape of this bacterium is called?



Exercise 4.2 Surveys of Prokaryotes

A. Yogurt

Yogurt is a product of a team work of two bacteria: *Streptococcus thermophilus* and *Lactobacillus bulgaricus*. These two bacteria extract energy from sugar molecules in milk. The name of *Streptococcus* indicates that this bacterium is _____ shape. *Lactobacillus* indicates that it has _____ shaped cell.

Materials

Diluted yogurt culture, blank slide, cover slip and water
Prepared slide: Yogurt smear

Procedure

1. Make a diluted yogurt wet mount slide by adding two drops of culture to a blank slide and cover it with a cover-slip.
2. Observe the wet mount slide and the prepared slide under the microscope.

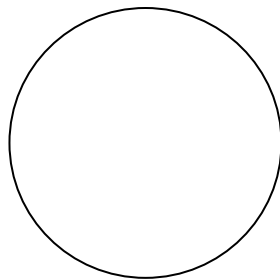

Streptococcus thermophilus (1,000x)

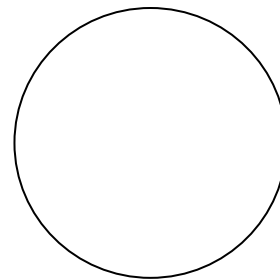

Lactobacillus bulgaricus (1,000x)

B. Cyanobacteria

Cyanobacteria are also called blue-green algae. The bluish pigment phycocyanin (phycobilin) gives cyanobacteria the color. Most of cyanobacteria exist as filaments or colonies. Some filamentous form of cyanobacteria use a specialized cell called **heterocyst** to fix nitrogen.

Materials

Living culture and Prepared slides: *Anabaena* *Gloeocapsa*

Procedure

1. Use page 28 of your *A photographic Atlas for the Biology Laboratory* to identify these two organisms.
2. Make a wet mount of *Anabanea* and observe it under the microscope. **Label heterocyst and single cell.**
3. Make a wet mount of *Gloeocapsa* and observe it under the microscope. **Label sheath.**

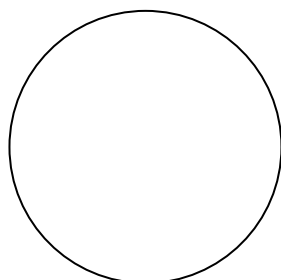

Anabanea (1,000 X)

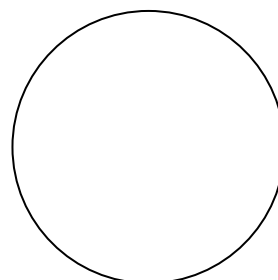

Gloeocapsa (1,000 x)

4. Answer the questions on your answer sheet.



Clean the slides with paper towel to remove immersion oil.
Clean your microscope lens with lens paper.

Return your microscope in the storage cabinet.

Exercise 4.3 Bacteria in Our Environment

Microbes live in many places. In this exercise, we will investigate the microbes that live around us. Also, we will investigate the growth conditions of these microorganisms.

Materials

Two nutrient agar plates/group Sterilized cotton tips in a tube.
Sterilized water

Procedure

1. Label the two Petri dishes (at the edges of the plate bottoms) with your initials.
2. Label the one plate with 37°C and another plate with 0°C.
3. Pick an environment you would like to survey. Examples are: your oral cavity, bathroom door knob, classroom door knob, and a dollar bill etc.
4. Place the name of the environment on the side of your plates.
5. Place the sterilized cotton tip in sterilized water to make it wet.
6. Swipe the area that you want to survey with the wet cotton tip.
7. Open one plate and spread the microbes as shown in (Figure 1). Close the cover.
8. Repeat steps 5 and 6 with the second plate.
9. Seal the edge of Petri dishes with Parafilm.
10. Turn in your Petri dishes to your instructor.
11. Check your results in next class period.

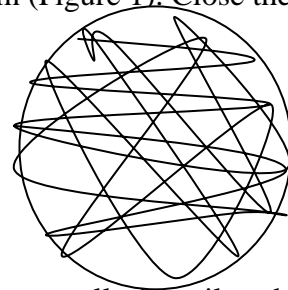

Figure 1 Spreading Microbes

Expected Results

Smooth colonies are possible bacterial colonies.

- Pink or orange colony: *Serratia Marcescens* occurs naturally in soil and water as well as the intestines. It is associated with urinary and respiratory tract infections, endocarditis, osteomyelitis, septicemia, wound infections, eye infections, meningitis.
- Yellow colony: *Micrococcus luteus* can be found in many places such as the human skin, water, dust, and soil. *Micrococcus* is generally thought of as harmless bacterium, but there have been rare cases of *Micrococcus* infections in people with compromised immune systems, as occurs with HIV patients.
- Cream colony: *Escherichia coli*
- White colony: *Staphylococcus epidermis* is nonpathogenic and occurs on the skin of humans and animals and in mucous membranes.
- Most of fuzzy colonies are fungi such as *Penicillium*.

Reference

<http://bbwiki.tamu.edu/index.php?title=Escherichia coli>

Lab 4 Answer Sheet

(Turn this in with Lab 5 Answer Sheet Do not forget research the questions)

Name _____

Exercise 4.1 Cell Structure

1. You were not able to see the sub-cellular structures so use your text book. Finish the labels of the diagram.

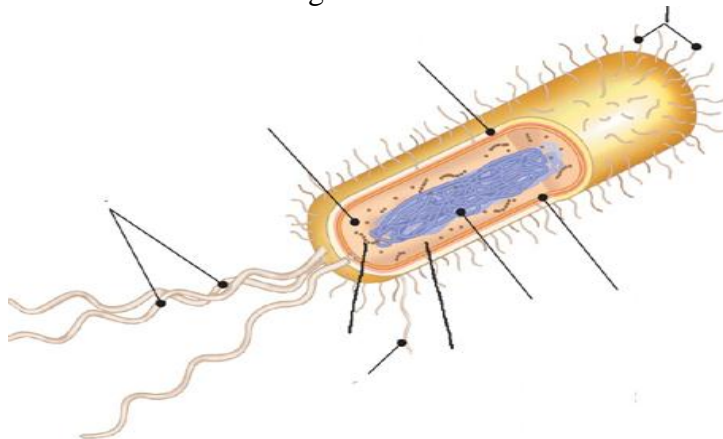

2. What make a bacterium a gram negative bacterium?

Exercise 4.2 Surveys of Prokaryotes

1. What gives cyanobacterium its color? _____

2. Results

Table 4.1 Bacterial Growth (complete the next lab period).

Plate	37°C	0°C
Bacterial colony* number		
Colony shape		
Colony color		

- Colony looks like a circle on the agar plates. If you have too much growth to count, record as “Lawn” growth.
- Bacteria grow better under _____ temperature.

Research

- a. What types of bacteria cause tooth decay? _____
- b. What types of bacteria are used to make cheese? _____

Lab 5 Protists

Name _____

Pre lab Readings

1. Reece et.al. 2012 *Biology* Chapter 28 pages 578-596
2. Perry and Morton (1996) *Photo Atlas for Biology* pages 18-22; 32-39

Protists are simple eukaryotes. Most of them are unicellular. There are multicellular forms as well. They are very diverse in cellular organization, metabolic activities and habitats.

Objectives

1. To learn the cellular structure of protists.
2. To survey diversity of protists.

Materials

Prepared slides	<i>Giardia</i>	<i>Trypanosoma</i>	<i>Amoeba</i>	<i>Euglena</i>
	<i>Paramecium</i>	<i>Vovlox</i>	<i>diatom</i>	
Live culture	<i>Amoeba</i>	<i>Euglena</i>	<i>Paramecium</i>	
Specimen	brown and red algae, marine algae comparison			
Other	detain, well slides			

Exercise 5.1 Excavates

Protists in these clades with _____ and lack _____.

Giardia lamblia (also known as *G. intestinalis*) is a parasite that causes Giardiasis (GEE-are-DYE-uh-sis). Symptoms include diarrhea and upset stomach or nausea. The parasitic form is called trophozoites. It inhabits in the small intestine of the host and it is the motile feeding stage. Cysts are passed in the feces of an infected host. Cysts are resistant to adverse environmental conditions. They can be ingested by unsuspected hosts when they consume contaminant food or water. Each cyst produces two trophozoites in the host body.

Procedure

I. Diplomonads and parabasalids

- A. Place the slide *G. lamblia* under the microscope.
- B. Observe the number of nuclei.
- C. Draw a diagram and show nuclei.



Cyst

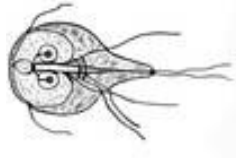

Trophozoite

G. lamblia (trophozoite) 450 x

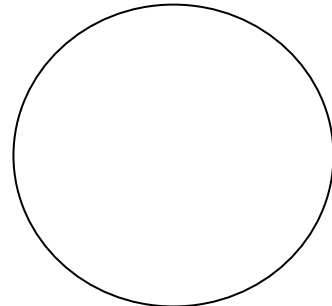

II. Euglenozoan

- A. Kinetoplastids: *Trypanosoma*

Trypanosoma has a single large _____. It causes the Africa sleepiness disease. There are many species of *Trypanosoma* in this genus. However the most of them have similar life cycle. According to <http://www.biosci.ohio-state.edu/~parasite/trypanosoma.html>, “the parasite grows and reproduces as a trypomastigote form in the blood of the infected host. When a vector ingests trypomastigotes during a blood meal, the trypomastigotes transform into epimastigotes and grow and reproduce in the vector’s gut or salivary glands. The epimastigotes transform into trypomastigotes, and these infect a new host the next time a vector takes a blood meal. The various life cycle stages of the different species of *Trypanosoma* are virtually indistinguishable morphologically”.

Procedure

1. Place the prepared *Trypanosoma* slide under the microscope. Observe the nucleus (N) and kinetoplast (KP).
2. Draw one diagram of *Trypanosoma* and label nucleus and kinetoplast.

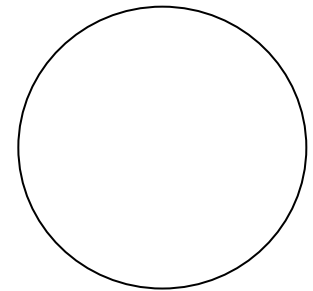
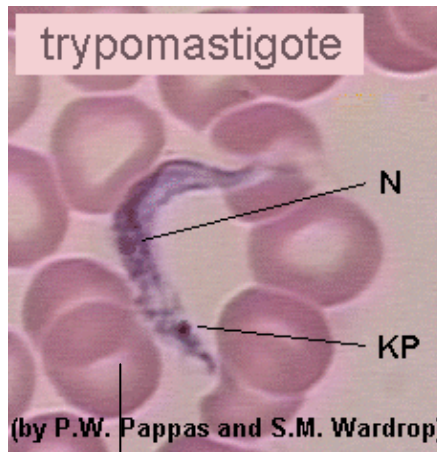
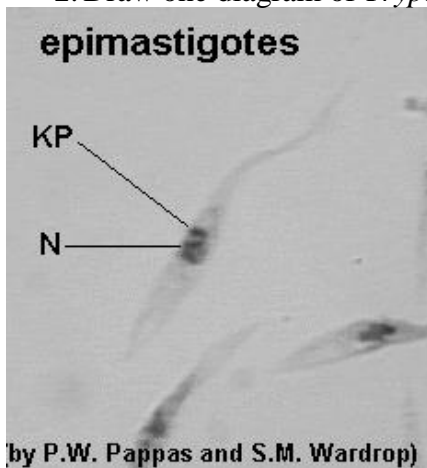

Trypanosoma (450x)

Blood cell

B. Euglenid: *Euglena*

Euglena has chloroplasts, eye spot and two flagella to move about. They store paramylon, a polysaccharide which is unique for this group. Normally, these organisms conduct photosynthesis. They can also be heterotrophs.

Procedure

1. Place the *Euglena* slide under the microscope and observe its structure.
2. Make a wet mount of *Euglena* by adding two drop of live culture of *Euglena* and one drop of “detain” on your blank slide. Cover with the cover slip.
3. Observe the movement of *Euglena* under the microscope.
4. Draw a diagram. **Label chloroplast, eye spot and flagella.**

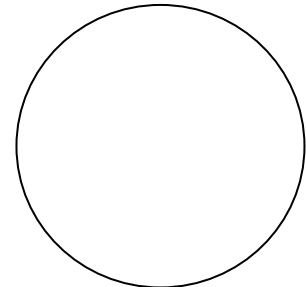

Euglena (450 x)

Exercise 5.3 Chromalveolates: Alveolates

Ciliates are named after their locomotion tools **cilia**. A distinctive feature of ciliates is that they have two types of nuclei. The **macronuclei** are in charge of daily activities while **micronuclei** function in conjugation process.

Procedure

1. Observe the prepared *Paramecium* slide under the microscope.
2. Make a wet mount of *Paramecium* (use Detain).
3. Observe the movement under the microscope.
4. Use Figure 22.e *Photo Atlas for Biology* reference.
5. Draw a diagram of *Paramecium* and **label cilia and nuclei**.

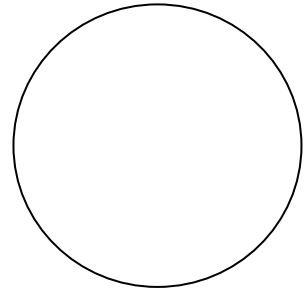

Paramecium (450 x)

Exercise 5.4 Chromalveolates: Stramenopile

A. Diatoms

Diatoms are autotrophic organisms. Their distinctive features include **silica** embedded cell wall. They store their food as **laminarin** (a polymer of glucose).

Procedure

1. Observe the prepared diatom slide under your microscope.
2. Reference figures can be found on page 34 of your photographic atlas or displayed chart.
3. Draw a few diatoms in a diagram.

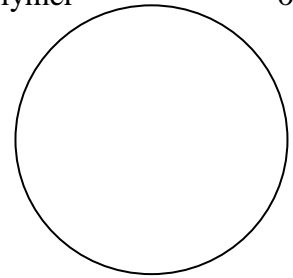

Diatom (450 x)

B. Brown algae

Brown algae are the largest marine algae. The pigments called **carotenoids** (fucoxanthin) give them the brown or olive color. They are multicellular and most are marine. They have a complex life cycle called **alternation of generation**. The brown algae in display are diploid sporophytes (spores producing individuals). It produces the zoospores. The zoospores then develop into male and female gametophytes (gametes producing individuals) that produce sperms and eggs.

Procedure

1. Observe the specimen display in class.
2. Name of one displayed specimen: _____
3. What make the brown algae brown? _____

Exercise 5.5 Unikonts: Amoebozoans

Amoebas are heterotrophs that move by means of lob-shaped **pseudopodia**.

Procedure

1. Observe prepared slide of Ameoba.

2. Draw a diagram of *Amoeba*. **Label pseudopodia and nucleus.**
3. Identify the pseudopodia.
4. Find an *Amoeba* under the dissecting microscope.
5. Make a wet mount of *Amoeba* by using a well slide; do not place the cover slip on.
6. Observe **it under the lower objective.**

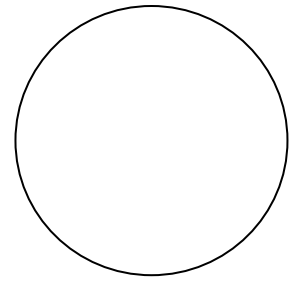

Amoeba (100 x)

Exercise 5.6 Chlorophyta Algae and Rhodophyta

Green algae (Chlorophyta) are close relative of land plants. Chlorophyll pigments give them the color in which they are named after. *Volvox* is a colonial type of green algae. Each of the large colonial balls contains smaller colonies.

Red algae have pigment called phycoerythrin to give its reddish green color in shallow water; red color in moderate deep water and blackish color in deep water

Procedure

1. Observe the prepared slide of *Volvox*.
2. Make a wet mount slide of *Volvox*.
3. **Draw a diagram of *Volvox*.**
4. In **live** culture, the color of *Volvox* is _____.
5. Observe other displays in class.
6. Red algae have _____ pigments that given them the red color.

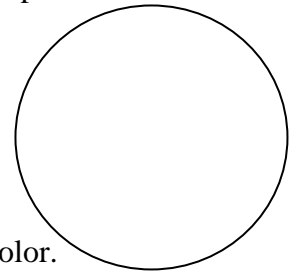

Volvox (100 x)

Exercise 5.7 Mystery Protists

In this exercise, you will need to use the characteristics of different Protists and identify the name of live protists in the unknown jar.

Materials

Live unknown culture

Procedure

1. Observe the unknown under the dissecting microscope.
2. Make a wet mount of the unknowns.

Table 5.2 Unknowns

Diagram/Sketch	Unknown Name	Clade	Reasons

Diagram/Sketch	Unknown Name	Clade	Reasons

References

http://biology.dbs.umt.edu/biol103/labs/Christian/5a_the_protists.htm

http://www.cdc.gov/ncidod/dpd/parasites/giardiasis/factsht_giardia.htm

Trypanosoma <http://www.biosci.ohio-state.edu/~parasite/trypanosoma.html>

Lab 6 Pre-lab Questions

1. What is prothallus or prothllium?

2. *Mnium* is the genus name of _____.

Lab 6 Plant Diversity I –Seedless Plants

Name _____

Pre-lab Readings

1. Reece et.al. 2011. *Biology* Chapter 29.
2. Perry and Morton (1996) *Photo Atlas for Biology* pages 41-53

Objectives

1. To learn the structure of seedless plants
2. To understand the life cycles of seedless plants.
3. To survey different types of seedless plants.

Plants are multicellular and photosynthetic organisms. Land plant evolved from green algae. The critical steps to make the transition from aquatic to land require the development of structures that prevent desiccation and provide support to plant bodies. These adaptive structures include waxy cuticles that cover plant surfaces to retain water; stomata that allow gas exchange; vascular tissues to transport water and nutrients, and to support plant bodies. Later air borne pollens and seeds were developed in seed plants to carry sperms to female reproductive structures.

Exercise 6.1 Non –Vascular Plants

Primitive plants such as bryophytes lack vascular tissues such as xylem and phloem. The dominant stage of their life cycles is gametophytes (N). Most of these plants live in very moist environment. This group of non vascular plants includes three phyla (divisions): Bryophyta (mosses), Hepatophyta (liverworts) and Anthoceroophyta (hornworts). There are about 10,000 species of mosses, 6,500 species of liverworts and 100 species of hornworts. Please note that sometime the word “bryophytes refer to only mosses.

Materials

Prepared slides: *Minum* (moss) antheridial and archegonial heads
Marchantia (liverwort) thallus
Live Specimen: Moss (gametophyte and sporophyte) Liverwort

Procedures

- A. Observe the prepared slides of moss antheridial and archegonial heads.
- B. Draw one diagram of antheridium and **label the sperm**. Draw a diagram of archegonium and **label the egg**.

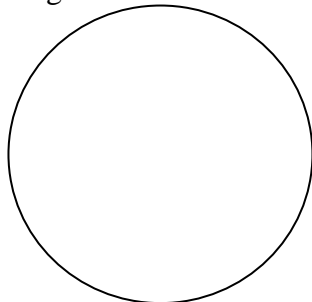

Antheridium (100 x)

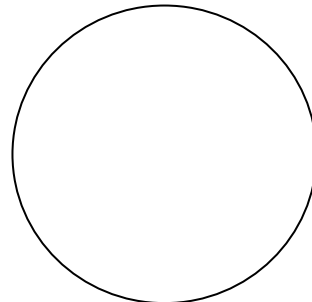

Archegonium (100 x)

C. Observe the displayed moss and tape a small piece of moss gametophyte here:

D. Tape a small piece of liverwort gametophyte here:

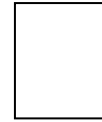
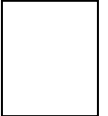

E. Label the following diagrams with the words **gametophyte**, **sporophyte**, **moss** and **liverwort**.

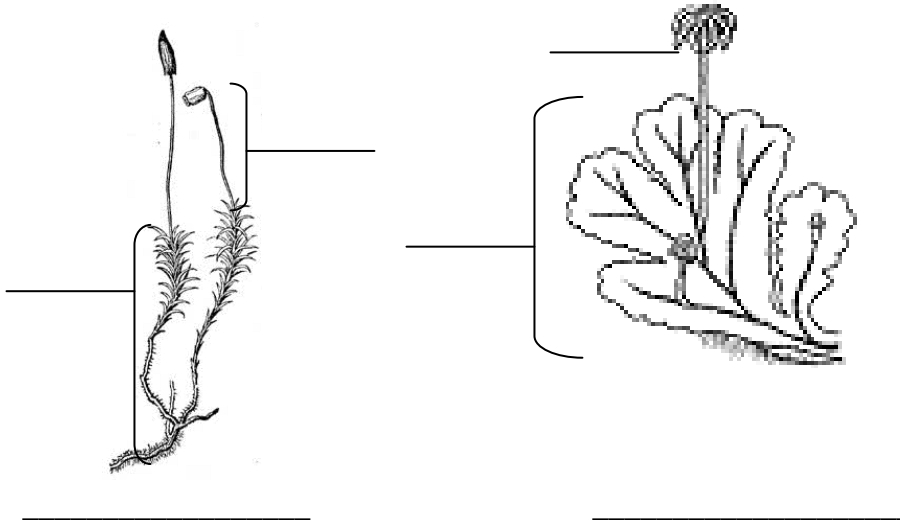

Exercise 6.2 Seedless Vascular Plants

Seedless vascular plants are currently placed in Phylum *Pteridophyta* in *Reece et al.* 2011 *Biology*. *Pteridophytes* include *Lycophyta* (club mosses), *Sphenophyta* (Horsetails) and *Pterophyta* (ferns). They have developed vascular tissues, leaves and roots. There are 12,000 species of ferns, 100 species of club mosses and only 15 species of horsetails.

Materials

Prepared slides Fern prothallus (flat gametophyte stage)

Typical fern leaflet and sorus section

Typical fern rhizome, (c.s.)

Specimen Fern leaf with sori

Horsetail with strobilus

Procedures

A. Observe the prepared slides of fern leaflet cross section. Label **leaflet**, **sporangium**, and **indusium**.

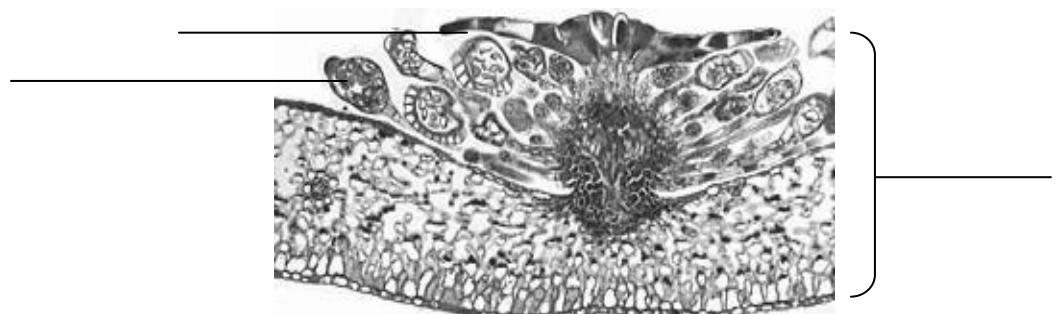

B. Observe the fern displays. Remove a piece of leaflet and tape it here. **Label the leaflet and a sorus.**



B. Observe fern prothallus (a flat gametophyte) slide and label the following diagram with the words: **antheridia**, **archegonia**, **gametophyte** and **rhizoid** and **fern**.

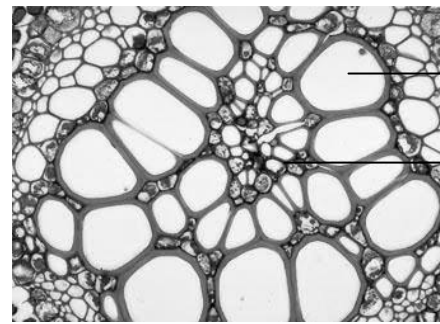
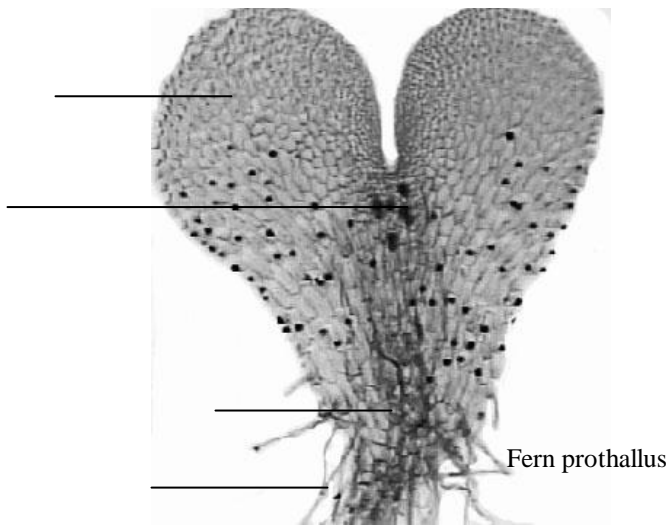

Fern rhizome (c.s) 400x

C. Observe fern rhizome slide and label the diagram with terms **xylem** and **phloem**.

D. Record the displayed specimen in Table 6.1.

Table 6.1 Displayed Specimens

Name	Phylum
	Hepatophyta
	Bryophyta
	Pterophytes
	Pterophytes

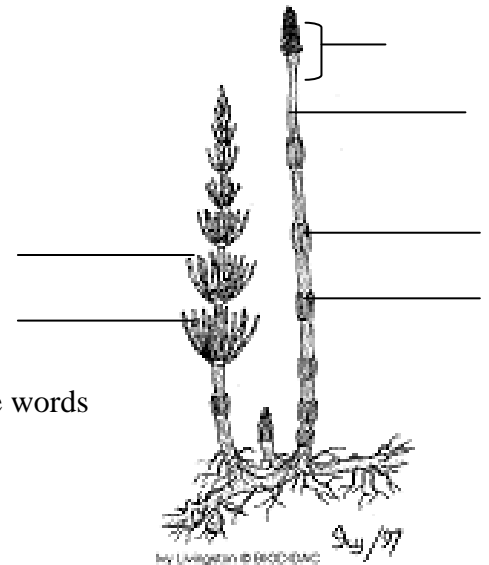

F. Complete the label of horsetail diagram by using the words of **leaf**, **stem**, **branch** and **rhizoid**.

Exercise 6.3 Mystery Species

Professor Armstrong was driving on High way 395 along the eastern side of the Sierra Nevada in late summer. He noticed the red, salt flats of Owens Lake gleaming in the desert sun. What kind of organism can live this kind of hostile environment? So he stopped his car and collected some red dirt. Back to school, he placed his specimen under the microscope. He found two organisms as shown in Figure 1. Organism 1 is a red organism that lacks both nucleus and peptidoglycan in its cell wall. Unknown 2 is a green color organism.

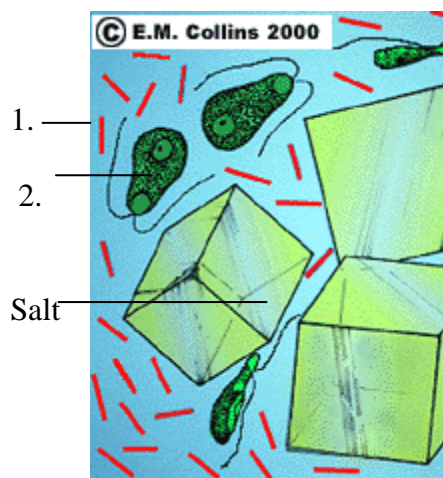

Figure 1 Organisms under microscope

Table 1 Mystery Species Observations

Size (microscopic or macroscopic)	Unknown 1	Unknown 2
Presence of nucleus (yes/no)		
Color of the organism (see the color picture posted on bulletin board)		
Describe the shape of the cell.		
Does this organism appear to have locomotion structures? (yes/no)		
Does this organism have cell wall? (yes/no)		
How does this organism move?		
How many cells are these organisms made of ? (one/many)		

1. Unknown 1 belongs to domain _____

What other characteristics do you need to know to narrow down the organism to its clades?

2. Unknown 2 belongs to domain _____

1) List what clades do you expect them to be?

2) And explain what other characteristics you need to narrow your decisions?

Answer Questions

1. How does moss reproduce sexually?

2. How do liverworts reproduce asexually (research on internet)?

3. How do ferns reproduce sexually?

4. What is a Spanish moss?

5. Why do ferns grow larger than moss?

Lab 7 Prelab Questions

1. What is a seed?

2. Where do you find male and female gametophyte in seed plants?

Los Angeles Valley College Campus Field Trip
(Turn in with Lab 7)

Name _____

1. List nonvascular plants.

Name	Phylum

2. List seedless plants.

Name	Phylum

3. List gymnosperms.

Name	Phylum

4. List angiosperms plants observed on campus.

Name	Clade

5. Poisonous plants

a. _____ b. _____

6. Edible plants

a. _____ b. _____

7. List animals observed on campus.

1) Reptiles

a. _____ b. _____

2) Birds

a. _____ c. _____

b. _____ d. _____

3) Mammals

a. _____ b. _____

Lab 7 Plant Diversity II – Seed Plants

Name _____

Pre-lab Reading

1. Reece et.al. 2011. *Biology* Chapter 30
2. Perry and Morton (1996) *Photo Atlas for Biology* pages 54-58

Objectives

1. To investigate the different types of seed plants.
2. To learn the life cycles of seed plants.

Seeds plants have vascular tissues and are able to produce seeds. Seeds are fertilized ovules. In seed plants, gametophytes are much reduced and they depend on sporophyte to survive. The female gametophyte is embryo sac. The pollen grain contains male gametophyte. The dominant stage is sporophyte generation. The evolution of pollen grain enable the plants reproduce without water. The embryo containing seeds are very well protected by female reproductive structure. In this lab, we will explore various seed plants.

Exercise 7.1 Gymnosperms

Gymnosperms have “naked” seeds since these seeds are not enclosed by fruits. Their seeds are produced by female cone. The dominant stage is the diploid sporophyte. There are four common phyla of gymnosperms as describes in your lecture book. We will focus on two phyla: Ginkgophyta and Coniferophyta

Materials

Prepared slides	Pine Stem, tangential section or macerate pine leaf (c.s.) pine male strobilus with pollen (c.s.) pine young female strobilus medium (l.s.) pine mature embryo (l.s.)
Specimen	Male and female cones of pine Ginkgo leaf

Procedure

- A. Observe the prepared pine strobilus (staminate cone) with pollen under the scope.
- B. Draw one section of diagrams of *Pinus* staminate cone and **label pollen sac, pollen grain and microsporophyll.**
- C. Draw a portion of *Pinus* female strobilus cone or ovulate cone and **lable ovuliferous scale, ovule, sterile bract, integument, megaspore and megasporangium.**
- D. Identify pine leaf structure.
 - a. Observe the prepared pine leaf cross section slide under the microscope and use the diagram on the right to identify the leaf structure.

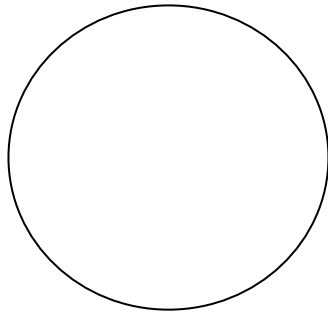

Pine staminate cone (40 x) c.s.

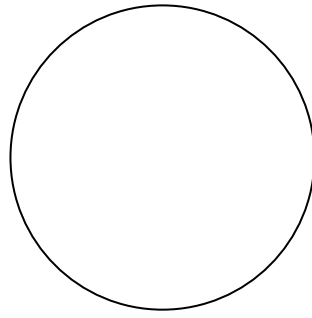

Pine pollen (400x)

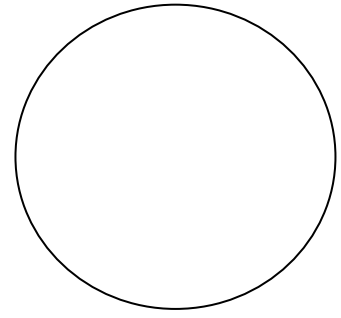

Pine ovule (100 x) l.s.

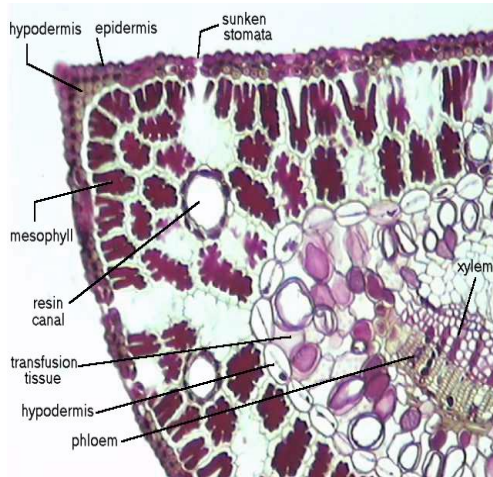

Figure 1 Pine leaf (c.s)

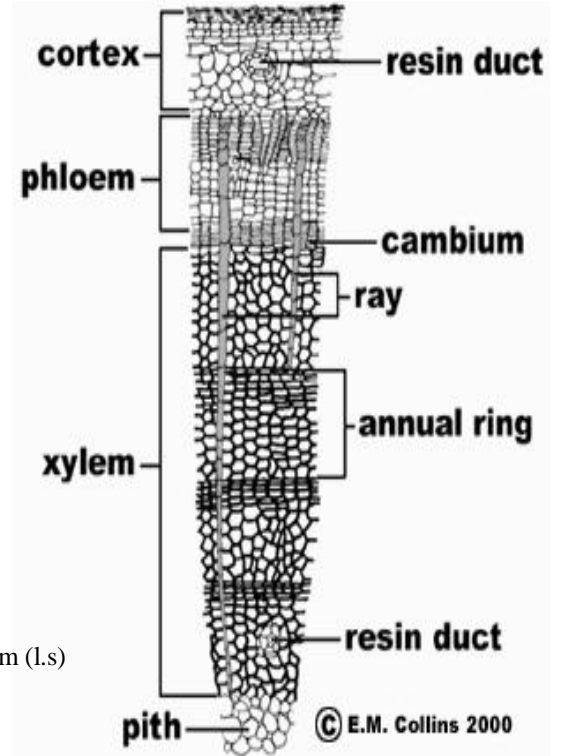
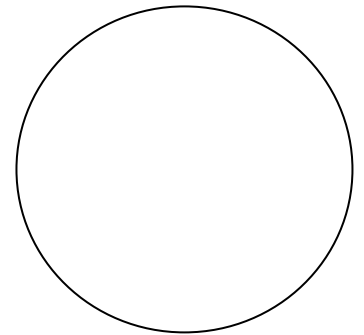

Figure 2 Pine stem (l.s)

- E. Identify the structures of pine stem.
- Observe the pine stem prepared slide under the microscope.
 - Use the diagram on the right to identify the stem structure.
- F. Observe the displays and draw one **ginkgo leaf** in the provided circle.
- G. Complete the questions in your answer sheet.



Ginkgo leaf

Exercise 7.2 Angiosperms

Angiosperms are enclosed seed plants. They are also called **flowering plants**. The flower is made of modified leaves. A typical flower has four whorls. From the outside to inside, there are sepals, petals, stamens and carpel. Flower plants are coevolved with pollinators. Fertilized ovules form seeds. Mature ovary form fruit. They have a unique **double fertilization**; as a result a nutritive endosperm is formed. They have differentiated vascular tissues and two pollen sacs in their anthers. The angiosperms are the most diverse plants on earth. There are about 260,000 species. The diversity of angiosperms includes basal angiosperms, magnoliids, monocot and eudicots.

Materials

Prepared slides: Pollen types
Flowers

Procedures

A. Flower Development

1. Observe mixed pollen types slide.
 - a. Draw a diagram of eudicot and monocot pollen grains under high power.
 - b. How are monocot pollen grains different from eudicot pollen grains?

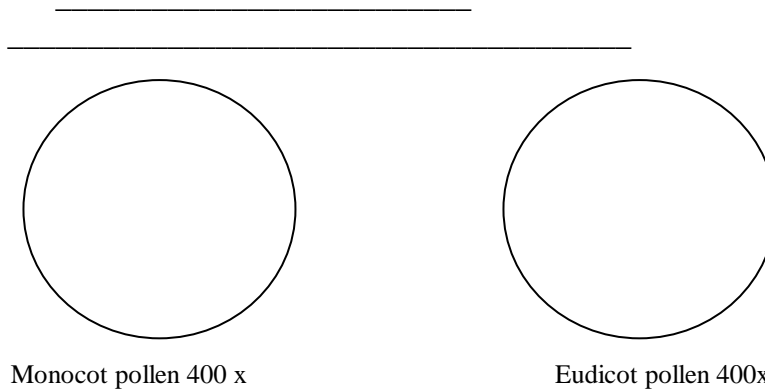

B. Flower and Pollinator

During the process of reproduction, pollen is transferred to stigma of a flower, pollination occurs. Flowers have distinct shape, color, and fragrance to attract the animals. Some pollinators tend to be attracted to certain types of flowers. As a matter of fact, plants coevolve with the pollinators.

Table 7.1 summarizes these cues from human perspectives. Of course, animals are opportunists. They may go for the non typical flowers as well.

Table 7.1 Pollination and Floral Adaptation

Pollination Method	Visual Characteristics	Chemical Characteristics
Wind	Dull colored, small, flowers often group in a cluster, stigma feathery	none

Pollination Method	Visual Characteristics	Chemical Characteristics
Bat (night)	Large dull or white flowers	Odors: fruity, fermenting
Bee	Bright colors such as yellow, pink, orange and blue, flowers with ultraviolet marking, irregular flowers with “landing platform	Sweet
Beetles	Dull or white colored	Strong odors: ranging from fruity, spicy to foul
Butterflies	Bright colors such as red, pink, orange, yellow, blue; flowers often long tubular; sometime forms a cluster for landing	Strong odor: sweat
Flies	Large flowers, dull or reddish color	Rotten meat or foul odor
Hummingbirds	Red, yellow tubular flowers	Sugary nectar, odor or odorless

1. Observe and record the displayed flowers and their possible pollinators listed above.

Table 7.2 Flowers and Pollinators

Plant name	Speculated pollinator	Justify your answers

C. Flower Dissection

Procedure

1. Use the same displayed flowers.
2. Use your dissection tool to take the flower apart.
3. Paste **one** example for each floral part in the space below.

Name	Sepal	Petal	Stamen	Carpel	Monocot Or Dicot

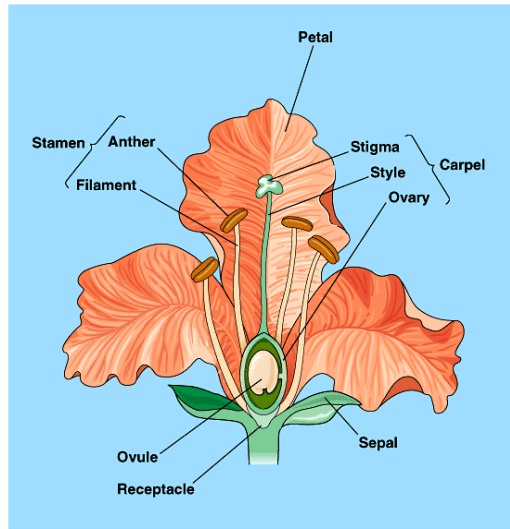

Copyright © Pearson Education, Inc., publishing as Benjamin Cummings.

Figure 3. A typical flower

Answer Questions

1. Analyze the structure of pine leaf and stem; explain why pine trees are drought resistant?

2. Review the life cycles in your lecture book and fill in the blanks.

TABLE 1 COMPARISON OF LIFE CYCLES

Characteristics	Bryophytes	Pterophyta	Gymnosperms	Angiosperms
Examples				
Vascular Tissue (Yes/No)				
Rhizoids /Roots				
True leave (Yes/No)				
Flagellated sperm (Yes/No)				
Dominant generation (sporophyte/gametophyte)				
Seed				
Pollen				
Flower and fruit				